

# TWO ROLLS ROLLING MACHINE DV 10/2.5

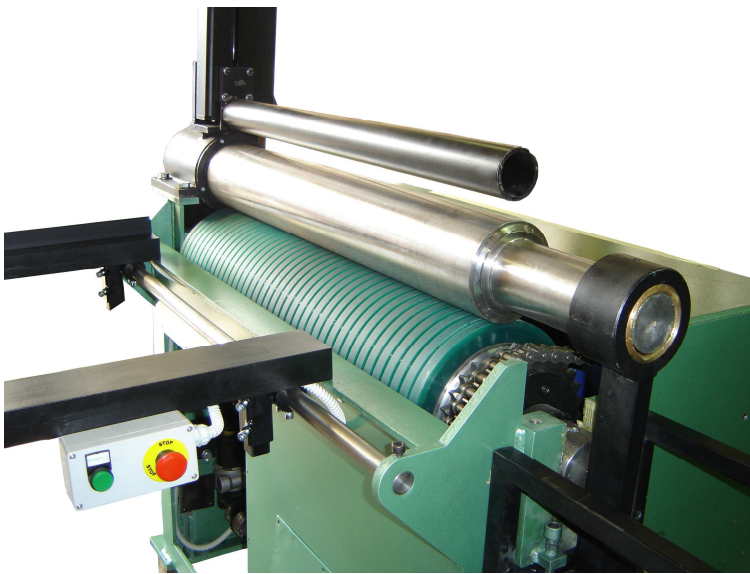
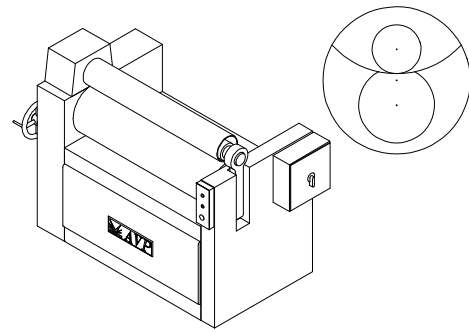
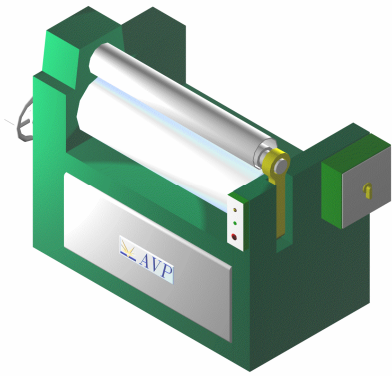

## Use

- for rolling (curving) coats (boilers, fire extinguishers, tubes, air reservoir, small pressure vessels,...)

## Properties:

- rolling in one crossing
- ideal roundness without straight starts and ends
- high productivity

## Data:

Rolling width:	1000 mm
Sheet metal thickness:	max 2,5 mm
Min. diameter:	approx. 200 mm
Rolling speed:	9m/min
Movement of polyurethane cylinder:	hydraulic
Power supply:	5,5 KW
Weight:	1.400 kg

**AVP d.o.o.**      **Welding automation**

Cesta v Log 15, 1351 Brezovica pri Ljubljani / SLOVENIJA

tel: +386 1514 04 10, fax: +386 1 514 04 12    e-mail: [info@avp.si](mailto:info@avp.si)    [www.avp.si](http://www.avp.si)